

# USB-2623

Analog Input and Digital I/O Measurement and Control

## User's Guide

## Trademark and Copyright Information

Measurement Computing Corporation, InstaCal, Universal Library, and the Measurement Computing logo are either trademarks or registered trademarks of Measurement Computing Corporation. Refer to the Copyrights & Trademarks section on [mccdaq.com/legal](http://mccdaq.com/legal) for more information about Measurement Computing trademarks. Other product and company names mentioned herein are trademarks or trade names of their respective companies.

© 2019 Measurement Computing Corporation. All rights reserved. No part of this publication may be reproduced, stored in a retrieval system, or transmitted, in any form by any means, electronic, mechanical, by photocopying, recording, or otherwise without the prior written permission of Measurement Computing Corporation.

### **Notice**

Measurement Computing Corporation does not authorize any Measurement Computing Corporation product for use in life support systems and/or devices without prior written consent from Measurement Computing Corporation. Life support devices/systems are devices or systems that, a) are intended for surgical implantation into the body, or b) support or sustain life and whose failure to perform can be reasonably expected to result in injury. Measurement Computing Corporation products are not designed with the components required, and are not subject to the testing required to ensure a level of reliability suitable for the treatment and diagnosis of people.

---

# Table of Contents

<b>Preface</b>	
<b>About this User's Guide .....</b>	<b>5</b>
What you will learn from this user's guide .....	5
Conventions in this user's guide .....	5
Where to find more information .....	5
<b>Chapter 1</b>	
<b>Introducing the USB-2623 .....</b>	<b>6</b>
Functional block diagram .....	7
<b>Chapter 2</b>	
<b>Installing the USB-2623 .....</b>	<b>8</b>
Unpacking.....	8
Installing the software .....	8
Installing the hardware .....	8
Configuring the hardware.....	8
Calibrating the hardware.....	9
Field calibration .....	9
Factory calibration .....	9
<b>Chapter 3</b>	
<b>Signal Connections.....</b>	<b>10</b>
68-pin SCSI connector P1 .....	10
Cabling.....	11
Signal termination.....	11
40-pin header connectors J2, J4, and J5.....	12
Cabling.....	13
Signal termination.....	13
<b>Chapter 4</b>	
<b>Functional Details .....</b>	<b>14</b>
Analog input modes.....	14
Software paced.....	14
Hardware paced .....	14
Burst mode.....	14
USB-2623 components.....	15
68-pin SCSI connector P1.....	15
40-pin header connectors J2, J4, and J5 .....	16
USB connector.....	16
LEDs.....	16
Standoffs.....	16
Signal descriptions.....	16
Analog input .....	16
Digital I/O.....	16
Counter input .....	18
Trigger input .....	18
Timer output .....	18
Ground.....	18
Power output.....	18
USB power .....	18
Mechanical drawing .....	19
<b>Chapter 5</b>	
<b>Specifications .....</b>	<b>20</b>
Analog input .....	20

Accuracy.....	20
Analog input DC voltage measurement accuracy .....	20
Noise performance.....	21
Settling time for multichannel measurements .....	21
Analog input calibration .....	21
Digital input/output.....	21
External trigger .....	22
External clock .....	22
Counter .....	22
Timer output .....	23
Memory .....	23
Power.....	23
USB .....	23
Environmental .....	24
Mechanical .....	24
Signal connections.....	24
68-pin SCSI connector (P1).....	25
40-pin header connectors (J2, J4, J5).....	26
Standoff locations.....	27

## About this User's Guide

### What you will learn from this user's guide

This user's guide describes the Measurement Computing USB-2623 data acquisition device and lists device specifications.

### Conventions in this user's guide

**For more information**

Text presented in a box signifies additional information related to the subject matter.

**Caution!** Shaded caution statements present information to help you avoid injuring yourself and others, damaging your hardware, or losing your data.

**bold text**     **Bold** text is used for the names of objects on a screen, such as buttons, text boxes, and check boxes.

*italic text*     *Italic* text is used for the names of manuals and help topic titles, and to emphasize a word or phrase.

### Where to find more information

For additional information relevant to the operation of your hardware, refer to the Documents subdirectory where you installed the MCC DAQ software (C:\Program Files\Measurement Computing\DAQ by default), or search for your device on our website at [www.mccdaq.com](http://www.mccdaq.com).

## **Introducing the USB-2623**

The USB-2623 is a USB 2.0 high-speed device that is supported under the Microsoft® Windows® operating system.

The USB-2623 is compatible with both USB 1.1 and USB 2.0 ports. The speed of the device may be limited when using a USB 1.1 port due to the difference in transfer rates on the USB 1.1 versions of the protocol (low-speed and full-speed).

The USB-2623 device provides the following features:

- 16 single-ended (SE) analog inputs
- 24 DIO channels; bit configurable for input or output
- Four counter inputs
- Four timer outputs
- Digital trigger input
- External AI scan clock input
- External AO scan clock input
- One 68-pin SCSI connector and three 40-pin header connectors for field wiring connections

The USB-2623 is powered by the USB supply from the computer; external power is not required.

## Functional block diagram

USB-2623 functions are illustrated in the block diagram shown in Figure 1.

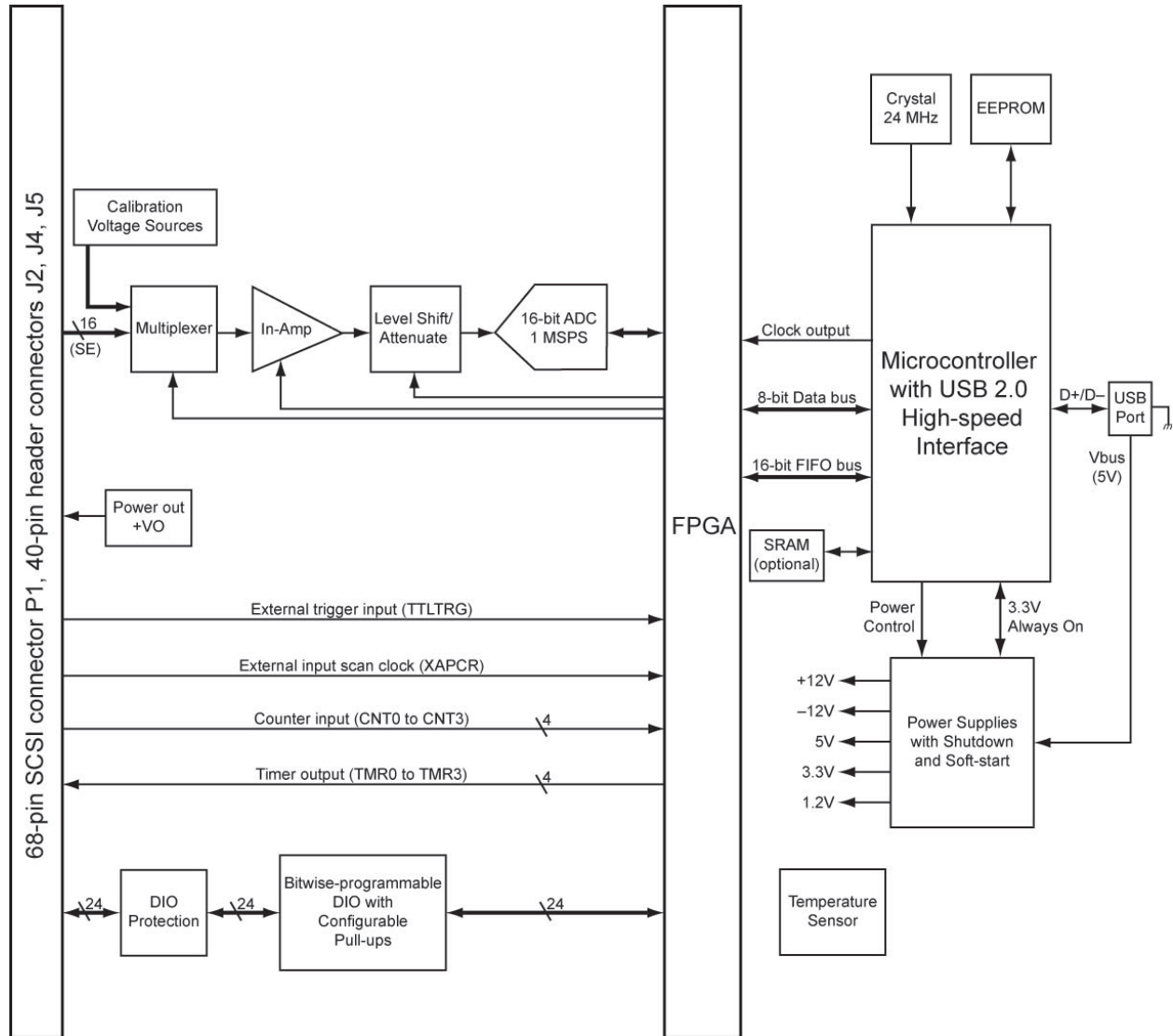

Figure 1. USB-2623 functional block diagram

# Installing the USB-2623

## Unpacking

As with any electronic device, you should take care while handling to avoid damage from static electricity. Before removing the device from its packaging, ground yourself using a wrist strap or by simply touching the computer chassis or other grounded object to eliminate any stored static charge.

Contact us immediately if any components are missing or damaged.

## Installing the software

Refer to the *MCC DAQ Quick Start* and the USB-2623 product page on our website for information about the software that supports the device.

### **Install the software before you install your device**

The driver needed to run the USB-2623 is installed with the software. Therefore, you need to install the software package you plan to use before you install the hardware.

## Installing the hardware

To connect a USB-2623 device to your system, turn on your computer and connect the USB cable to an available USB port on the computer or to an externally powered USB hub connected to the computer.

When connected for the first time, a **Found New Hardware** dialog opens when the operating system detects the device. When the dialog box closes, the installation is complete.

The **Power LED** (top LED) blinks during device detection and initialization, and then remains on. When the board is first powered on, there is usually a momentary delay before the Power LED blinks or turns on.

## Configuring the hardware

All hardware configuration options are programmable with software.

**Caution!** Avoid redundant connections. Ensure that there is no signal conflict between the 68-pin SCSI connector (P1) and the 40-pin connectors (J2 to J5). Failure to do so could possibly cause equipment damage and/or personal injury.

Turn off power to all devices connected to the system before making connections. Electrical shock or damage to equipment can result even under low-voltage conditions.

Always handle components carefully, and never touch connector pins or circuit components unless you are following ESD guidelines in an appropriate ESD-controlled area. These guidelines include using properly-grounded mats and wrist straps, ESD bags and cartons, and related procedures.

Avoid touching board surfaces and onboard components. Only handle boards by their edges. Make sure that the USB-2623 does not come into contact with foreign elements such as oils, water, and industrial particulate.

The discharge of static electricity can damage some electronic components. Semiconductor devices are especially susceptible to ESD damage.

## Calibrating the hardware

### Field calibration

The USB-2623 supports self-calibration. Run the InstaCal utility to calibrate the USB-2623 whenever the ambient temperature changes by more than  $\pm 10$  °C from the last self-calibration. The recommended calibration interval is one year. Calibrate the inputs before calibrating the outputs.

### Factory calibration

The Measurement Computing Manufacturing Test department performs the initial factory calibration. Return the device to Measurement Computing Corporation if you want the factory calibration restored.

## Signal Connections

Board signals are available on the 68-pin SCSI connector P1 and 40-pin header connectors J2, J4, and J5.

**Caution! Avoid redundant connections!** Make sure there is no signal conflict between the SCSI connector pins and header connector pins. Failure to do so could possibly cause equipment damage and/or personal injury.

### Use the SCSI cable for optimal analog input settling time

To achieve the best analog input channel-channel settling time performance, connect your signals to the SCSI connector (P1). If the J2 to J5 connectors are to be used, keep the interface cable as short as possible to minimize settling errors.

## 68-pin SCSI connector P1

The SCSI connector provides connections to the board signals listed in Figure 2.

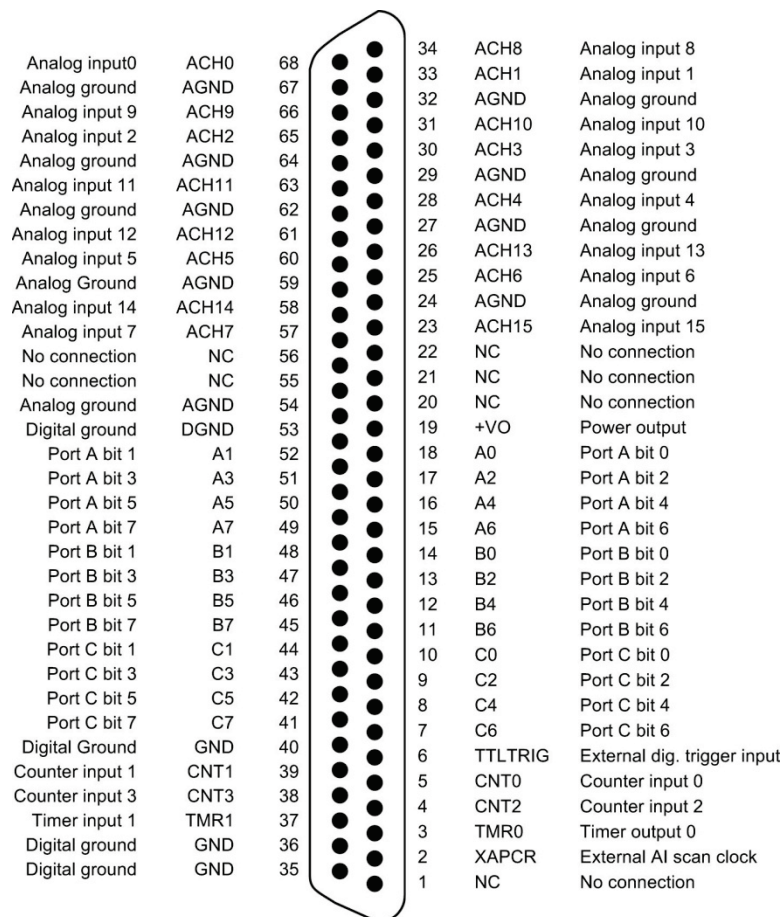

Figure 2. SCSI connector P1 pinout

### Cabling

Use a CA-68-3R cable (Figure 3) when connecting signals to the SCSI connector.

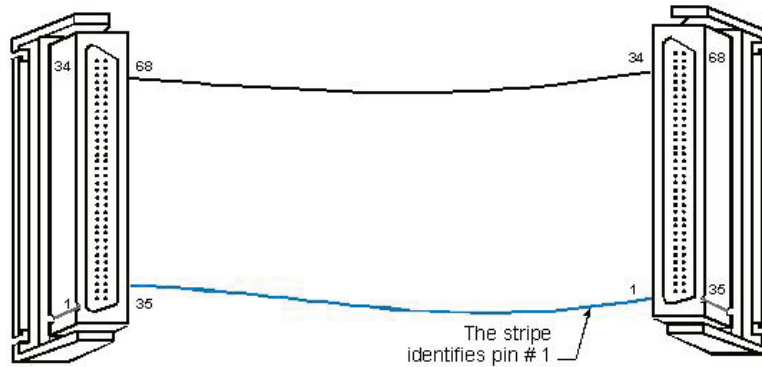

Figure 3. CA-68-3R cable

### Signal termination

- **TB-100** – screw terminal board that connects to SCSI connector P1 with a CA-68-3R cable. A 19-inch rack mount kit (**RM-TB-100**) is also available.

The following table lists how TB-100 screw terminals are mapped to the SCSI connector pins.

TB-100 to SCSI connector pin map

TB2 terminal	SCSI pin	TB1 terminal	SCSI pin
+5V	19	ACH0	68
GND	GND	ACH8	34
A0	18	AGND	AGND
A1	52	ACH1	33
A2	17	ACH9	66
A3	51	AGND	AGND
A4	16	ACH2	65
A5	50	ACH10	31
A6	15	AGND	AGND
A7	49	ACH3	30
B0	14	ACH11	63
B1	48	AGND	AGND
B2	13	ACH4	28
B3	47	ACH12	61
B4	12	AGND	AGND
B5	46	ACH5	60
B6	11	ACH13	26
B7	45	AGND	AGND
C0	10	ACH6	25
C1	44	ACH14	58
C2	9	AGND	AGND
C3	43	ACH7	57
C4	8	ACH15	23
C5	42	XDAC3 (Note 1)	56
C6	7	SGND	62
C7	41	NC (Note 2)	20
TTL TRG	6	XDAC2 (Note 1)	55
GND	GND	GND (Note 3)	GND
CNT0	5	AGND	AGND
CNT1	39	XDAC0 (Note 1)	22
CNT2	4	AGND	AGND

TB2 terminal	SCSI pin	TB1 terminal	SCSI pin
CNT3	38	XDAC1 (Note 1)	21
TMR0	3	AGND	AGND
TMR1	37	XAPCR	2
XDPCR (Note 1)	1	GND	GND
GND	GND	EGND	SCSI shell

Do not make connections to any terminal labeled NC.

Note 1: Not supported on the USB-2623  
 Note 2: Labeled POSREF on the TB-100; not supported on the USB-2623.  
 Note 3: Labeled NEGREF on the TB-100; not supported on the USB-2623.

### 40-pin header connectors J2, J4, and J5

The header connectors provide alternative connections to the 68-pin connector. Pins 1, 2, 39, and 40 are labeled on each connector.

**J2** provides analog input connections. **J4** provides digital, counter, timer, pacer input, and power output connections. **J5** provides timer, pacer I/O, and power output connections.

**Caution! Avoid redundant connections!** Make sure there is no signal conflict between the SCSI connector pins and header connector pins. Failure to do so could possibly cause equipment damage and/or personal injury.

Figure 4 shows the pinout for J2.

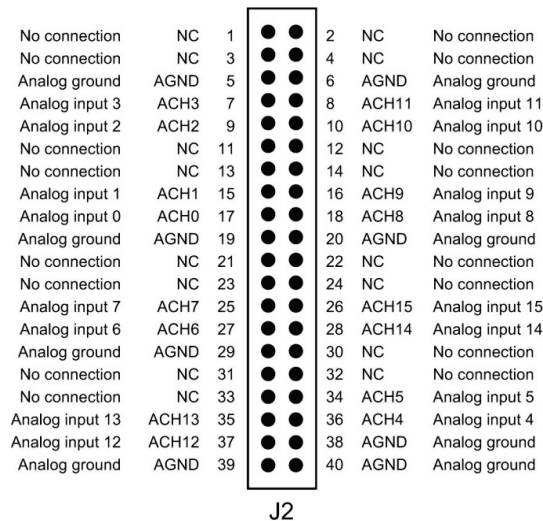

Figure 4. Header connector J2 pinout

Figure 5 shows the pinout for J4 and J5.

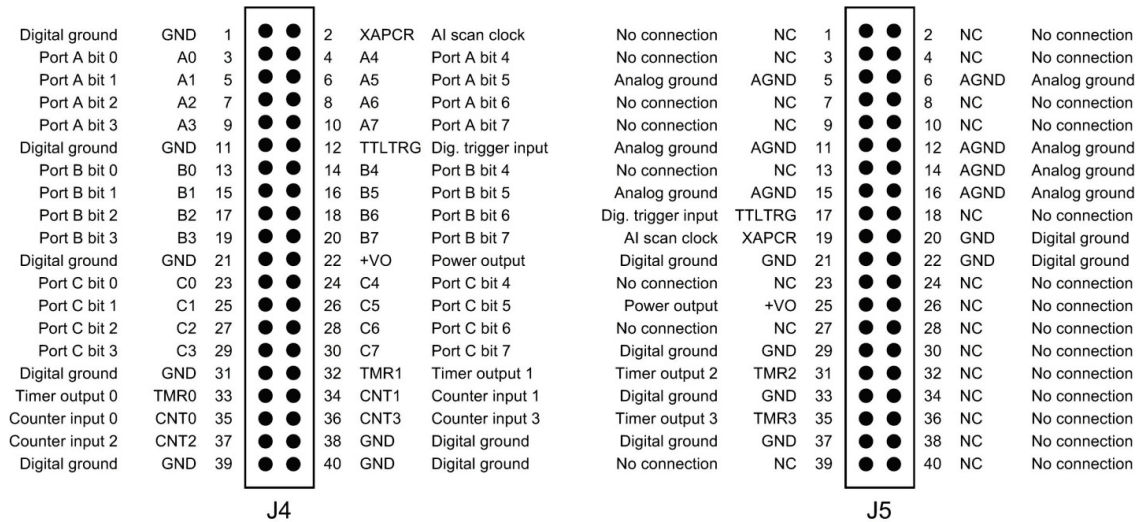

Figure 5. Header connector J4 and J5 pinout

**For more information about signal connections**

For more information about analog input connections, refer to the *Guide to DAQ Signal Connections* (available for download on our website at [www.mccdaq.com/support/DAQ-Signal-Connections.aspx](http://www.mccdaq.com/support/DAQ-Signal-Connections.aspx)).

**Cabling**

Use a C40FF-x cable (Figure 6) when connecting signals to a 40-pin header connector.

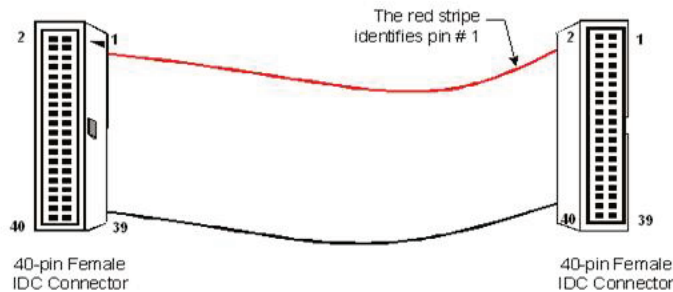

Figure 6. C40FF-x cable

Connecting a C40FF-x cable to each 40-pin connector provides greater signal connectivity than what is provided by the SCSI connector.

**Signal termination**

- **CIO-MINI40** – 40-pin screw terminal board that connects to the J2, J4, or J5 header connector with the C40FF-x cable.
- **TB-103** – screw terminal board that mounts directly onto the header connectors.

## Functional Details

### Analog input modes

The USB-2623 can acquire analog input data in two modes – software paced and hardware paced.

#### Software paced

You can acquire one analog sample at a time in software paced mode. You initiate the A/D conversion with a software command. The analog value is converted to digital data and returned to the computer. Repeat this procedure until you have the total number of samples that you want.

The sample rate in software paced mode is system-dependent and can range from 33 S/s to 4000 S/s.

#### Hardware paced

You can acquire data from up to 16 channels in hardware paced mode. The analog data is continuously acquired, converted to digital values, and written into the 4k FIFO buffer on the device until you stop the scan. The FIFO buffer is serviced in blocks as the data is transferred from the FIFO buffer to the computer memory buffer. You start a continuous scan with either a software command or with an external hardware trigger event.

The maximum sampling rate in hardware paced mode from one to 16 channels is 1,000 kS/s, max.

### Burst mode

Burst mode is an optional scan mode used with the onboard pacer to obtain more precise timing between samples. When burst mode is enabled, each successive channel in a scan is sampled at the maximum A/D rate. This ensures that samples from each channel are taken as close as possible to the same absolute point in time. When burst mode is disabled, data is sampled at evenly spaced intervals, allowing you to increase the sample period time; doing so can improve settling time and overall measurement accuracy.

Multi-channel scanning with burst mode enabled and disabled is shown in Figure 7.

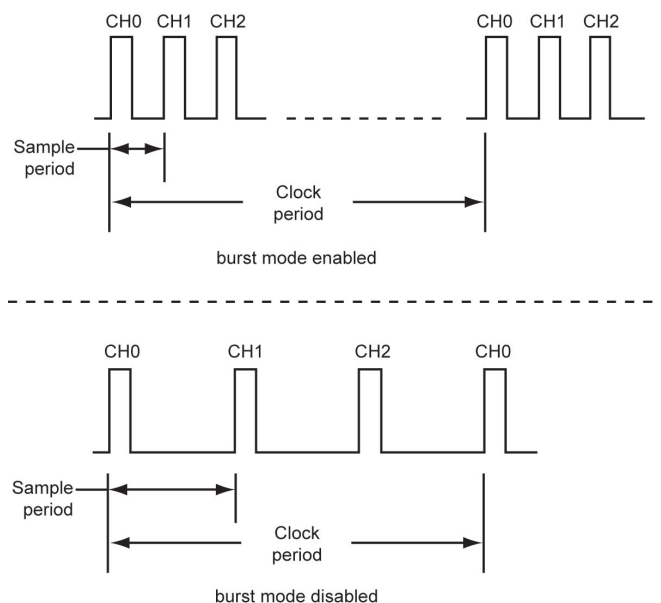

Figure 7. Multi-channel scan with burst mode enabled and disabled

The burst mode sample period is 1  $\mu$ s.

You can trigger the acquisition with the external trigger and control the clock period with the internal A/D pacer clock.

## USB-2623 components

These USB-2623 components are shown in Figure 8.

- 68-pin SCSI connector (P1)
- 40-pin header connectors (J2, J4, and J5)
- USB connector
- LED indicators (USB and Power)

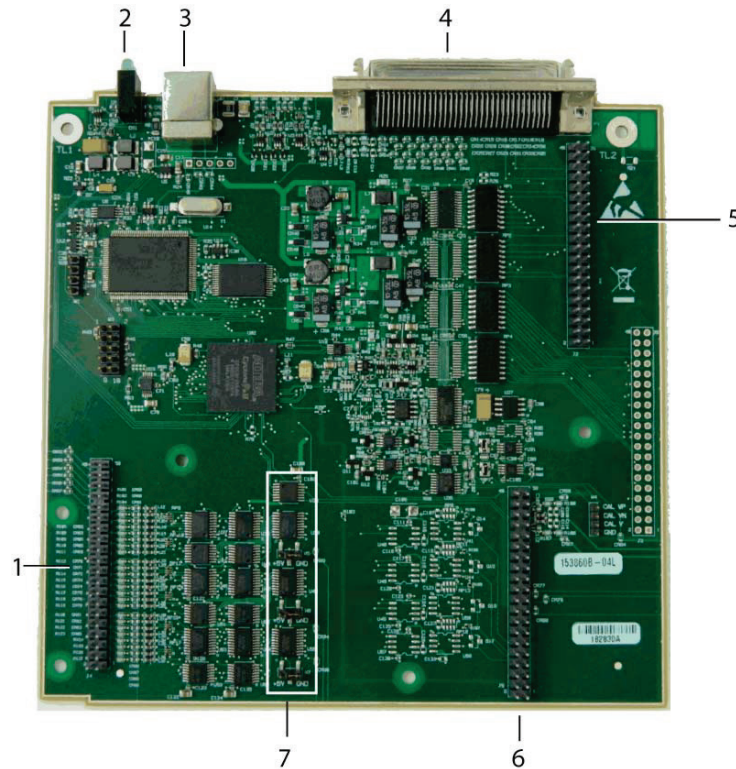

- |   |                          |   |                                   |
|---|--------------------------|---|-----------------------------------|
| 1 | 40-pin connector J4      | 5 | 40-pin connector J2               |
| 2 | LEDs                     | 6 | 40-pin connector J5               |
| 3 | USB connector            | 7 | Pull-up/down jumpers (W5, W6, W7) |
| 4 | 68-pin SCSI connector P1 |   |                                   |

Figure 8. USB-2623 components

### 68-pin SCSI connector P1

The 68-pin SCSI connector provides the following connections:

- 16 single-ended analog inputs (ACH0 to ACH15)
- 24 digital I/O (A0 to A7, B0 to B7, C0 to C7)
- Four counter inputs (CNT0 to CNT3)
- Two timer outputs (TMR0 to TMR1)
- External AI scan clock input (XAPCR)
- External AO scan clock input (XDPCR)
- External digital trigger input (TTLTRG)
- Power output (+VO)
- Analog ground and digital ground (AGND and GND)

Refer to Figure 2 on page 10 for the SCSI connector pinout.

## 40-pin header connectors J2, J4, and J5

The header connectors provide alternative connections to the SCSI connector.

- **J2** provides connections for the analog inputs.
- **J4** provides connections for the DIO, counter inputs, timer outputs, input scan clock, and power output.
- **J5** provides connections for the timer outputs, I/O scan clocks, and power output.

Refer to Figure 4 and Figure 5 on page 12 for header connector pinouts.

## USB connector

The USB connector provides +5 V power and communication. No external power supply is required.

## LEDs

The USB-2623 has two LEDs – **Power** and **Activity**.

- The **Power** LED (top) turns on when the device is detected and installed on the computer.
- The **Activity** LED (bottom) blinks when data is transferred and is off otherwise.

## Standoffs

The board is shipped with standoffs that can be used to mount the board onto a metal frame.

## Signal descriptions

### Analog input

The USB-2623 has a 16-bit A/D converter and provides 16 single-ended analog inputs. The input voltage range is fixed at  $\pm 10$  V. Analog input connections are available on the SCSI connector and on header connector J2:

- Both SCSI connector P1 and header connector J2 provide connections for **ACH0** to **ACH15**

### Input pacer clock

You can pace input scanning operations using the input scan clock on the board or with an external signal connected to **XAPCR**. The sampling rate is software-selectable for 0.0149 Hz to 1 MHz.

### Channel-Gain queue

The USB-2623 channel-gain queue feature allows you to configure a list of channels to scan. The settings are stored in a channel-gain queue list that is written to local memory on the device.

The channel-gain queue list can contain up to 16 elements. The channels can be listed in any order. An example of a 4-element list is shown in the table below.

Sample channel-gain queue list

Element	Channel	Range
0	CH5	BIP10V
1	CH1	BIP10V
2	CH15	BIP10V
3	CH7	BIP10V

## Digital I/O

The USB-2623 has 24 TTL-level digital I/O lines that are configured as three 8-bit ports. Each bit is configurable as either input or output. Digital I/O connections are available on the SCSI connector and header connector J4.

You can read digital input ports asynchronously before, during, or after an analog input scan. Digital outputs can be updated asynchronously before, during, or after an acquisition.

### Pull-up/down configuration

Each digital port has 47 kΩ resistors that are jumper configurable as pull-up or pull-down (default). Jumper **W7** configures Port A, **W6** configures Port B, and **W5** configures Port C.

**Caution!** Turn off power to all devices connected to the system before making connections. Electrical shock or damage to equipment can result even under low-voltage conditions.

Always handle components carefully, and never touch connector pins or circuit components unless you are following ESD guidelines in an appropriate ESD-controlled area. These guidelines include using properly-grounded mats and wrist straps, ESD bags and cartons, and related procedures.

Avoid touching board surfaces and onboard components. Only handle boards by their edges. Make sure that the USB-2623 does not come into contact with foreign elements such as oils, water, and industrial particulate.

The discharge of static electricity can damage some electronic components. Semiconductor devices are especially susceptible to ESD damage.

Figure 9 shows the location of each jumper on the board.

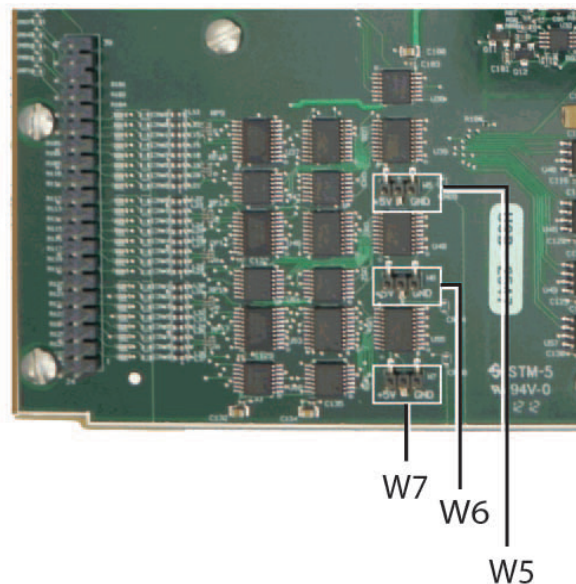

Figure 9. Pull-up/down jumper locations

Figure 10 shows the pull-up and pull-down configuration for each jumper.

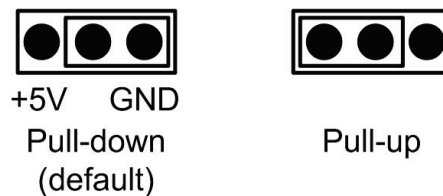

Figure 10. Pull-up/down jumper configurations

#### For more information about digital signal connections

For general information about digital signal connections and digital I/O techniques, refer to the *Guide to DAQ Signal Connections* (available for download on our website at [www.mccdaq.com/support/DAQ-Signal-Connections.aspx](http://www.mccdaq.com/support/DAQ-Signal-Connections.aspx)).

## Counter input

The four counter inputs (**CNT0** to **CNT3**) are 32-bit event counters that can accept frequency inputs up to 20 MHz.

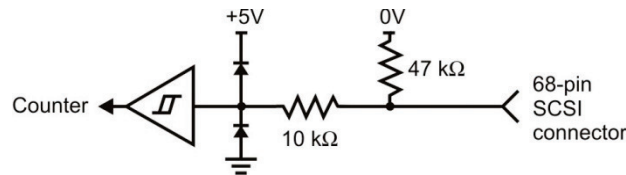

Figure 11. Typical counter input

Counter input connections are available on the SCSI connector and header connector J4.

## Trigger input

The external digital trigger input (**TTLTRIG**) is software selectable for edge or level sensitive.

- Edge sensitive mode is configurable for rising or falling edge.
- Level sensitive mode is configurable for high or low level.

The default setting at power up is edge sensitive, rising edge. The trigger input connection is available on the SCSI connector and header connectors J4 and J5.

## Timer output

The four timer outputs (**TMR0** to **TMR3**) are pulse width modulation (PWM) outputs that can generate a square wave with a programmable frequency in the range of 0.015 Hz to 32 MHz. Figure 12 shows the timer output schematic.

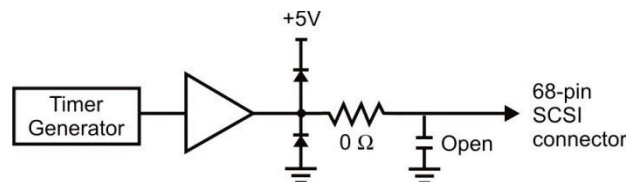

Figure 12. Typical timer output

Timer output connections are available on the SCSI connector and header connectors J4 and J5. TMR0 and TMR1 are available on the SCSI connector and header connector J4. TMR2 and TMR3 are available on header connector J5.

## Ground

The analog ground (**AGND**) pins provide a common ground for all analog channels. The digital ground (**GND**) pins provide a common ground for the digital, counter, timer, and clock channels and the power terminal.

## Power output

The **+VO** pin can output up to 10 mA maximum. Use this terminal to power external devices or circuitry. Power output connections are available on the SCSI connector and header connectors J4 and J5.

**Caution!** The **+VO** (+5V) terminal is an output. Do not connect to an external power supply or you may damage the device and possibly the computer.

## USB power

The maximum current that can be drawn by the device is 500 mA. This maximum applies to most personal computers and self-powered USB hubs. Bus-powered hubs and notebook computers may limit the maximum available output current to 100 mA. If the current requirement of the device exceeds the current available from the computer, connect to a self-powered hub or power the computer with an external power adapter.



## Specifications

All specifications are subject to change without notice.

Typical for 25 °C unless otherwise specified.

Specifications in *italic text* are guaranteed by design.

### Analog input

Table 1. General analog input specifications

Parameter	Condition	Specification
A/D converter type		Successive approximation
ADC resolution		16 bits
Number of channels		16 single-ended
Input voltage range		$\pm 10$ V
<i>Absolute maximum input voltage</i>	<i>CHx relative to AGND</i>	<ul style="list-style-type: none"> <li>■ <math>\pm 25</math> V max (power on)</li> <li>■ <math>\pm 10.5</math> V max (power off)</li> </ul>
<i>Input impedance</i>		<ul style="list-style-type: none"> <li>■ 1 G<math>\Omega</math> (power on)</li> <li>■ 390 <math>\Omega</math> (power off)</li> </ul>
<i>Input bias current</i>		$\pm 100$ pA
Input bandwidth	Small signal (–3 dB)	3.1 MHz
<i>Input capacitance</i>		40 pF
Maximum working voltage		$\pm 10.1$ V max relative to AGND
Crosstalk	Adjacent channels, DC to 10 kHz	–80 dB
Input coupling		DC
Sampling rate		0.0149 Hz to 1,000 kHz; software selectable
Trigger source		TTLTRG
A/D pacing		<ul style="list-style-type: none"> <li>■ Internal input scan clock</li> <li>■ External input scan clock (XAPCR)</li> </ul>
Burst mode		Burst rate = 1 $\mu$ s, software selectable
Throughput	Software paced	33 S/s to 4,000 S/s typ; system dependent
	Hardware paced	1 MS/s max
Channel queue		Up to 16 element list of random channels
Warm-up time		15 minutes min

### Accuracy

#### Analog input DC voltage measurement accuracy

Table 2. DC Accuracy components and specifications. All values are ( $\pm$ )

Range	Gain error (% of reading)	Offset error ( $\mu$ V)	INL error (% of range)	Absolute accuracy at Full Scale ( $\mu$ V)	Gain temperature coefficient (% reading/ $^{\circ}$ C)	Offset temperature coefficient ( $\mu$ V/ $^{\circ}$ C)
$\pm 10$ V	0.031	915	0.0076	4775	0.0013	35

## Noise performance

For the peak-to-peak noise distribution test, a single-ended input channel is connected to AGND at the input terminal block, and 32,000 samples are acquired at the maximum rate.

Table 3. Noise performance specifications

Range	Counts	LSBrms
±10 V	8	1.21

## Settling time for multichannel measurements

Settling time is defined as the accuracy that can be expected after one conversion when switching from a channel with a DC input at one extreme of full scale to another channel with a DC input at the other extreme of full scale.

Table 4. Input settling time specifications in  $\mu$ S, typical

Range	1 $\mu$ S settling accuracy (% FSR)	5 $\mu$ S settling accuracy (% FSR)	10 $\mu$ S settling accuracy (% FSR)
±10 V	0.0152	0.0061	0.0015

## Analog input calibration

Table 5. Analog input calibration specifications

Parameter	Specification
Recommended warm-up time	15 minutes min
Calibration method	Self-calibration (firmware)
Calibration interval	1 year (factory calibration)
AI calibration reference	+5 V, ±2.5 mV max. Actual measured values stored in EEPROM.
	Tempco: 5 ppm/°C max
	Long term stability: 15 ppm/1,000 hours

## Digital input/output

Table 6. Digital input/output specifications

Parameter	Specification
Digital type	TTL
Number of I/O	24
Configuration	Three banks of 8. Each bit may be configured as input (power on default) or output.
Pull-up configuration	Each port has 47 k $\Omega$ resistors that are configurable as pull-up or pull-down (default) using an onboard jumper (W5, W6, W7).
Digital I/O transfer rate (system-paced, asynchronous)	33 to 4,000 port reads/writes or single bit reads/writes per second typ; system dependent.
Input high voltage	2.0 V min 5.0 V absolute max
Input low voltage	0.8 V max 0 V recommended min
Output high voltage	4.4 V min (IOH = -50 $\mu$ A) 3.76 V min (IOH = -24 mA)
Output low voltage	0.1 V max (IOL = 50 $\mu$ A) 0.44 V max (IOL = 24 mA)
Output current	60 mA max, not to exceed 24 mA for one bit, resulting in 2.5 mA max when all 24 bits are enabled.

## External trigger

Table 7. External trigger specifications

Parameter	Specification
Trigger source	TTLTRG
Trigger mode	Software programmable for edge or level sensitive, rising or falling edge, high or low level. Power on default is edge sensitive, rising edge.
Trigger latency	1 $\mu$ s + 1 clock cycle max
Trigger pulse width	100 ns min
Input type	33 $\Omega$ series resistor and 49.9 k $\Omega$ pulldown to GND
Input high voltage	2.2 V min 5.5 V absolute max
Input low voltage	1.5 V max -0.5 V absolute min 0 V recommended min

## External clock

Table 8. External clock I/O specifications

Parameter	Specification
Terminal name	XAPCR
Terminal type	Input, active on rising edge
Terminal description	Receives pacer clock from external source
Input clock rate	1 MHz max
Clock pulse width	100 ns min
Input type	33 $\Omega$ series resistor, 47 k $\Omega$ pull-down to GND
Input high voltage	2.2 V min 5.5 V absolute max
Input low voltage	1.5 V max -0.5 V absolute min 0 V recommended min

## Counter

Table 9. Counter specifications

Parameter	Specification
Terminal names	CNT0, CNT1, CNT2, CNT3
Number of channels	4 channels
Resolution	32-bit
Counter type	Event counter
Input type	33 $\Omega$ series resistor, 47 k $\Omega$ pull-down to GND
Input source	68 pin SCSI: CNT0 (pin 5), CNT1 (pin 39), CNT2 (pin 4), CNT3 (pin 38) 40 pin (J4): CNT0 (pin 35), CNT1 (pin 34), CNT2 (pin 37), CNT3 (pin 36)
Counter read/writes rates (software paced)	33 to 8,000 reads/writes per second typ; system dependent
Input high voltage	2.2 V min
Input low voltage	1.5 V max
Maximum input voltage range	-5 V to +10 V max
Input frequency	20 MHz max
High pulse width	25 ns min
Low pulse width	25 ns min

## Timer output

Table 10. Timer specifications

Parameter	Specification
Terminal name	TMR0, TMR1, TMR2, TMR3
Number of channels	4 channels
Timer type	PWM output with count, period, delay, and pulse width registers
Output value	Default state is idle low with pulses high, software selectable output invert
Input source	68 pin SCSI: TMR0 (pin 3), TMR1 (pin 37) 40 pin (J4): TMR0 (pin 33), TMR1 (pin 32) 40 pin (J5): TMR2 (pin 31), TMR3 (pin 35)
Internal clock frequency	64 MHz
Register widths	32-bit
High pulse width	10.42 ns min
Low pulse width	10.42 ns min
Output high voltage	4.4 V min (IOH = -50 $\mu$ A) 3.76 V min (IOH = -1.0 mA)
Output low voltage	0.1 V max (IOL = 50 $\mu$ A) 0.44 V max (IOL = 1.0 mA)
Output waveform	Square wave
Output rate	64 MHz base rate divided by $2^{32}$ ; software selectable

## Memory

Table 11. Memory specifications

Parameter	Specification
Data FIFO	4 kS analog input
Non-volatile memory	32 KB (30 KB firmware storage, 2 KB calibration/user data)

## Power

Table 12. Power specifications

Parameter	Condition	Specification
Supply current (Note 1, Note 2)	Quiescent current	280 mA
+VO output voltage range		4.25 V to 5.25 V
+VO output current		10 mA max

**Note 1:** This is the total quiescent current requirement for the device that includes up to 10 mA for the Status LED. This value does not include potential loading of the DIO bits or the +VO pin.

**Note 2:** USB 2.0 ports are required by USB 2.0 standards to supply 2500 mW (nominal at 5 V, 500 mA). Self-powered hubs and externally-powered root port hubs provide up to 500 mA of current for a USB device. Battery-powered root port hubs, such as in a laptop PC, provide 100 mA or 500 mA, depending on the manufacturer. If your laptop is constrained to the 100 mA maximum, you need to purchase a self-powered hub.

## USB

Table 13. USB specifications

Parameter	Specification
USB device type	USB 2.0 (high-speed)
Device compatibility	USB 1.1, USB 2.0
USB cable type	A-B cable, UL type AWM 2725 or equivalent. (min 24 AWG VBUS/GND, min 28 AWG D+/D-)

USB cable length	3 m (9.84 ft) max
------------------	-------------------

## Environmental

Table 14. Environmental specifications

Parameter	Specification
Operating temperature range	0 °C to 55 °C max
Storage temperature range	-40 °C to 85 °C max
Humidity	0% to 90% non-condensing max

## Mechanical

Table 15. Mechanical specifications

Parameter	Specification
PCB dimensions (L × W)	152.4 mm × 150.62 mm (6.00 × 5.93 in.)

## Signal connections

Table 16. Board connectors, cables, and terminal boards

Parameter	Specification
Connector type	P1: 68-pin standard SCSI TYPE III female connector J2, J4, J5: Three 40-pin header connectors AMP# 2-103328-0
Compatible cables	P1: CA-68-3R ribbon cable; 3 feet. J2, J4, J5: C40FF-x ribbon cable; x is length in feet.
Compatible terminal boards	TB-100: Connects to a CA-68-3R cable TB-103: Mounts directly onto the header connectors CIO-MINI40: Connects to a C40FF-x cable

**68-pin SCSI connector (P1)**

Table 17. P1 connector pinout

Pin	Signal name	Pin description	Pin	Signal name	Pin description
68	ACH0	Analog input 0	34	ACH8	Analog input 8
67	AGND	Analog ground	33	ACH1	Analog input 1
66	ACH9	Analog input 9	32	AGND	Analog ground
65	ACH2	Analog input 2	31	ACH10	Analog input 10
64	AGND	Analog ground	30	ACH3	Analog input 3
63	ACH11	Analog input 11	29	AGND	Analog ground
62	AGND	Analog ground	28	ACH4	Analog input 4
61	ACH12	Analog input 12	27	AGND	Analog ground
60	ACH5	Analog input 5	26	ACH13	Analog input 13
59	AGND	Analog ground	25	ACH6	Analog input 6
58	ACH14	Analog input 14	24	AGND	Analog ground
57	ACH7	Analog input 7	23	ACH15	Analog input 15
56	NC	No connection	22	NC	No connection
55	NC	No connection	21	NC	No connection
54	AGND	Analog ground	20	NC	No connection
53	GND	Digital ground	19	+VO	Power output
52	A1	Port A bit 1	18	A0	Port A bit 0
51	A3	Port A bit 3	17	A2	Port A bit 2
50	A5	Port A bit 5	16	A4	Port A bit 4
49	A7	Port A bit 7	15	A6	Port A bit 6
48	B1	Port B bit 1	14	B0	Port B bit 0
47	B3	Port B bit 3	13	B2	Port B bit 2
46	B5	Port B bit 5	12	B4	Port B bit 4
45	B7	Port B bit 7	11	B6	Port B bit 6
44	C1	Port C bit 1	10	C0	Port C bit 0
43	C3	Port C bit 3	9	C2	Port C bit 2
42	C5	Port C bit 5	8	C4	Port C bit 4
41	C7	Port C bit 7	7	C6	Port C bit 6
40	GND	Digital ground	6	TTLTRG	External digital trigger input
39	CNT1	Counter input 1	5	CNT0	Counter input 0
38	CNT3	Counter input 3	4	CNT2	Counter input 2
37	TMR1	Timer output 1	3	TMR0	Timer output 0
36	GND	Digital ground	2	XAPCR	External analog input scan clock
35	GND	Digital ground	1	NC	No connection

## 40-pin header connectors (J2, J4, J5)

Table 18. J2 connector pinout

Pin	Signal name	Pin description	Pin	Signal name	Pin description
1	NC	No connection	2	NC	No connection
3	NC	No connection	4	NC	No connection
5	AGND	Analog ground	6	AGND	Analog ground
7	ACH3	Analog input 3	8	ACH11	Analog input 11
9	ACH2	Analog input 2	10	ACH10	Analog input 10
11	NC	No connection	12	NC	No connection
13	NC	No connection	14	NC	No connection
15	ACH1	Analog input 1	16	ACH9	Analog input 9
17	ACH0	Analog input 0	18	ACH8	Analog input 8
19	AGND	Analog ground	20	AGND	Analog ground
21	NC	No connection	22	NC	No connection
23	NC	No connection	24	NC	No connection
25	ACH7	Analog input 7	26	ACH15	Analog input 15
27	ACH6	Analog input 6	28	ACH14	Analog input 14
29	AGND	Analog ground	30	NC	No connection
31	NC	No connection	32	NC	No connection
33	NC	No connection	34	ACH5	Analog input 5
35	ACH13	Analog input 13	36	ACH4	Analog input 4
37	ACH12	Analog input 12	38	AGND	Analog ground
39	AGND	Analog ground	40	AGND	Analog ground

Table 19. J4 connector pinout

Pin	Signal name	Pin description	Pin	Signal name	Pin description
1	GND	Digital ground	2	XAPCR	External analog input scan clock
3	A0	Port A bit 0	4	A4	Port A bit 4
5	A1	Port A bit 1	6	A5	Port A bit 5
7	A2	Port A bit 2	8	A6	Port A bit 6
9	A3	Port A bit 3	10	A7	Port A bit 7
11	GND	Digital ground	12	TTLTRG	External digital trigger input
13	B0	Port B bit 0	14	B4	Port B bit 4
15	B1	Port B bit 1	16	B5	Port B bit 5
17	B2	Port B bit 2	18	B6	Port B bit 6
19	B3	Port B bit 3	20	B7	Port B bit 7
21	GND	Digital ground	22	+VO	Power output
23	C0	Port C bit 0	24	C4	Port C bit 4
25	C1	Port C bit 1	26	C5	Port C bit 5
27	C2	Port C bit 2	28	C6	Port C bit 6
29	C3	Port C bit 3	30	C7	Port C bit 7
31	GND	Digital ground	32	TMR1	Timer output 1
33	TMR0	Timer output 0	34	CNT1	Counter input 1
35	CNT0	Counter input 0	36	CNT3	Counter input 3
37	CNT2	Counter input 2	38	GND	Digital ground
39	GND	Digital ground	40	GND	Digital ground

Table 20. J5 connector pinout

Pin	Signal name	Pin description	Pin	Signal name	Pin description
1	NC	No connection	2	NC	No connection
3	NC	No connection	4	NC	No connection
5	AGND	Analog ground	6	AGND	Analog ground
7	NC	No connection	8	NC	No connection
9	NC	No connection	10	NC	No connection
11	AGND	Analog ground	12	AGND	Analog ground
13	NC	No connection	14	NC	No connection
15	AGND	Analog ground	16	AGND	Analog ground
17	TTLTRG	External digital trigger input	18	NC	No connection
19	XAPCR	External analog input scan clock	20	GND	Digital ground
21	GND	Digital ground	22	GND	Digital ground
23	NC	No connection	24	NC	No connection
25	+VO	Power output	26	NC	No connection
27	NC	No connection	28	NC	No connection
29	GND	Digital ground	30	NC	No connection
31	TMR2	Timer output 2	32	NC	No connection
33	GND	Digital ground	34	NC	No connection
35	TMR3	Timer output 3	36	NC	No connection
37	GND	Digital ground	38	NC	No connection
39	NC	No connection	40	NC	No connection

## Standoff locations

The board is designed with standoff holes labeled TL1 to TL8.

- **TL1:** Standoff hole TL1 is connected directly to the J1 USB connector shield.
- **TL2:** Standoff hole TL2 is connected directly to the P1 SCSI connector shield (pin 69, pin 70). The SCSI connector shield and TL2 can also be connected to the board chassis ground guard trace using the R21 (OPEN by default) resistor location.
- **TL4-8:** Standoff holes TL4-TL8 are electrically isolated from the PCB.

Refer to the mechanical drawing in the hardware user guide for the location of these standoff holes.

**Measurement Computing Corporation**  
**10 Commerce Way**  
**Norton, Massachusetts 02766**  
**(508) 946-5100**  
**Fax: (508) 946-9500**  
**E-mail: [info@mccdaq.com](mailto:info@mccdaq.com)**  
**[www.mccdaq.com](http://www.mccdaq.com)**

**NI Hungary Kft**  
**H-4031 Debrecen, Hátar út 1/A, Hungary**  
**Phone: +36 (52) 515400**  
**Fax: +36 (52) 515414**  
**<http://hungary.ni.com/debrecen>**